

**OBSERVATIONS OF PRESSURE DIFFERENTIALS AND AIR FLOW RATES**  
**ASSOCIATED WITH INDOOR RADON FROM TWO PASSIVE RADON**  
**MITIGATION VENTS IN AN EXTENDED GRAVEL-BED FOUNDATION-TYPE**  
**LARGE BUILDING**

Kaiss K. Al-Ahmady

State of Florida, Department of Health and Rehabilitative Services  
Office of Environmental Toxicology, Radon and Indoor Air Toxics  
Tallahassee, FL

David E. Hintenlang

University of Florida, Department of Nuclear Engineering Sciences  
Gainesville, FL

**ABSTRACT**

Discrete and continuous measurement of indoor radon concentrations, air flow rates, and pressure differentials for passive and active operational configurations of a passive radon control system were performed at the Biotechnology Research and Development Facility of the University of Florida, in Alachua County, Florida. The system was installed during construction and incorporated an extended six-inch gravel bed underneath the entire foundation slab with upper and lower surfaces covered by reinforced polyethylene sheeting and vented by two vertical four-inch diameter metal vent pipes extended through the building roof. Pressure differentials were measured between the radon passive mitigation pipes and the outdoors and across mitigation pumps installed during the experiments. Air flow rates were continuously and simultaneously monitored at the radon vent pipes for different configurations of the building use. Measurements were performed using sensors that were integrated into an on-site data-logging system. Average indoor radon concentrations were reduced from above 4 pCi/l to approximately 3.5 pCi/l with concentrations exceed 4 pCi/l in some area, with only one system vent operating. The concentrations are further reduced by 36% with both vents operating. Concentrations are reduced by approximately 70% with a suction fan installed on one of the system vents while the other vent left capped. Evaluation of the measurement results for different testing configurations, and recommendation for aspects to be observed for designing similar passive radon mitigation systems are presented.

**INTRODUCTION**

The geology of Alachua County, Florida, have been assessed as favorable to the production of large amount of radon gas. Definite evidence of elevated radon potential was found in the county (Nagda et. al. 1989). A United States Environmental Protection Agency (EPA) statewide study placed the radon potential in the county in the category of moderately high (USEPA 1993). The Florida radon protection map for large buildings recommended that passive radon controls be utilized in the county for new construction, with some areas requiring both active and passive controls (Nielson et. al. 1996). A recent study of a large number of indoor radon testing results compiled by the Florida Department of Health and Rehabilitative Services indicated that average concentrations of 2.2 pCi/l exist countywide with 22.25% of the tested non-residential buildings exhibiting indoor radon concentration greater than 4 pCi/l (Al-Ahmady et. al. 1996).

Preventive measures undertaken by the University of Florida (UF) at Gainesville, Florida, Campus Planning and Construction Management, for the control of indoor radon in newly constructed buildings; includes in-situ soil gas-radon testing conducted prior to construction to determine the potential for future indoor radon problems in university's facilities. An assessment of the radon potential was conducted at the Biotechnology Research and Development Facility (BRDF), located in Alachua County, Florida, by testing of near-surface radon and evaluation of near-surface soil and geological conditions. Testing was performed by Southern Radon Services, Inc. in 1994 at the

proposed 6.5-acre site of the building, under a sub-contract for LAW Engineering and Environmental Services, Inc., the construction contractor.

Radon-222 testing results at 16 locations within the footprint of the proposed structure ranged from 1257 pCi/l to 3821 pCi/l with an average concentration of 2168 pCi/l. Passive radon protection controls were proposed that consist of utilizing polyethylene vapor barriers, control over sealing practices, gravel bed underneath the structure slab, and incorporation of two vertical vent pipes. Installation of the passive controls were conducted during construction by the contractor.

After the completion of construction, testing of indoor radon concentrations were performed by the UF's Environmental Health and Safety Division. Further monitoring of indoor radon concentrations, pressure differentials, and air flows from the passive control system were designed and independently conducted by the UF's Department of Nuclear Engineering Sciences as a part of a Florida Radon Research Program (FRRP) research project to evaluate building construction features for the control of indoor radon for the Florida Department of Community Affairs.

## METHODOLOGY

Soil-gas measurements were performed in 16 locations within the approximately 35,000 square feet of construction area as indicated in Figure 1. The site has a nearly level grade with upper soils classified as clayey sand. Testing was performed at a depth of 1.5 feet using an EDA RD-200 portable radon detector employing AnS(AG)-coated scintillation cells. Background level in the cells were checked prior to measurement and the final counting was adjusted accordingly. At a minimum three samples were collected at each of the testing sites to obtain a representative figure of soil-gas radon concentrations in that location.

The passive radon control system is comprised of a six-inch continuous porous layer (gravel bed) of clean coarse aggregate (ASTM size #5) that is located four inches under the slab inner surface. The area between the slab and the gravel bed is filled with compacted select screening with gradation to fine and coarse aggregate. The latter layer is not considered as a part of the PRCS since it is separated from the gravel bed by a one layer of six-mil reinforced polyethylene sheeting. Further, the lower surface of the gravel bed is separated from the rest of soils by two layers of 6-mil reinforced polyethylene sheeting. The resulting gravel layer, which extends to the foundation, forms the medium upon which air associated with the PRCS may flow. The gravel bed is vented via two vertical 4-inch diameter pipes (north and south wing vents) that extend through the roof of the building. The vent pipe base consists of an eight-inch thick block that houses the lower end of the vent pipes and provides the communication with the gravel medium. Since the radon control system was initially designed as a passive system, no pumps were installed into the vents. Figure 2 illustrates the foundation details of the PRCS.

Initial characterization and simultaneous measurement of time-integrated and time-dependent indoor radon concentration were performed upon the completion of the building and during different operational configurations of the PRCS. Honeywell professional radon monitors, E-PERMs, and Pylon AB-5 were used during the testing to measure the spatial dependence of indoor radon concentrations throughout the building. Passive operational configurations were designed to investigate air flow rates out of, and pressure differentials across the PRCS vents; and to characterize the communication between the system's two vents. Characterization of the passive system operation with regards to single and double venting were also performed. These configurations consist of capping and uncapping both vents, capping one vent and uncapping the other, and their combinations. Active operating configurations were designed to characterize the system response to forced air suction from the vent; as well as, to the air flow, pressure differentials, and the communication between the vents under forced air flow conditions. Indoor radon concentrations were simultaneously monitored under the passive and active operational configurations. The active configurations were conducted by installing a temporary fan (Fantech Model F/FR 150) at the upper portion of the vent pipe that extended through the building roof. Description of the passive and active testing configurations used in these experiments is shown in Table 1.

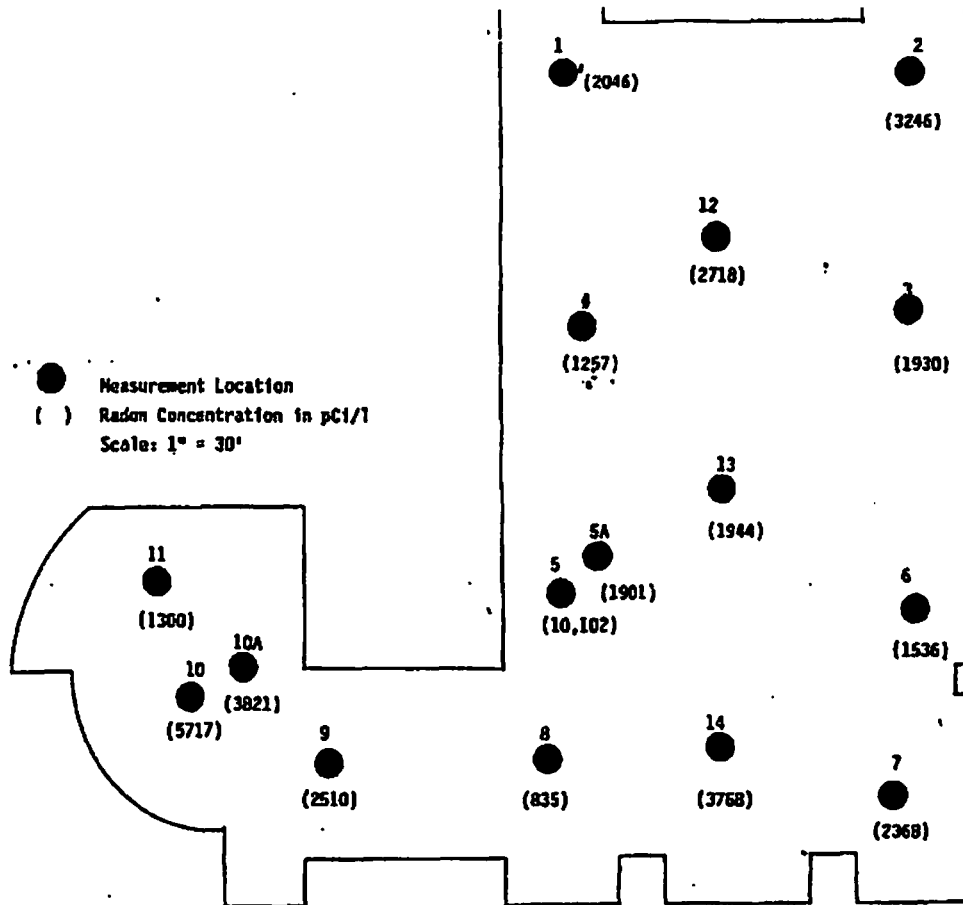

Figure 1: An illustration of the UF's BRDF layout and locations of soil-gas radon testing. The section to the left is the north wing and the rectangular-shape section to the right is the south wing.

An integrated portable data-logging station was designed and constructed for the purpose of the testing. A Campbell Scientific 21X data-logging system is used and programmed as a host of experiment control and data collection, while a pressure differential transmitter (Setra model C-264) and a linear air velocity transducer (KURZ model 435DC) were integrated into the system. All experiments were conducted over a minimum period of three days and repeated during the period of this research. Data were remotely retrieved through phone lines into a personal computer at the UF campus. Devices were checked at the beginning of each experiment and corrected if needed. Figure 3 shows a schematic diagram of the data-logging system assembly used in this research.

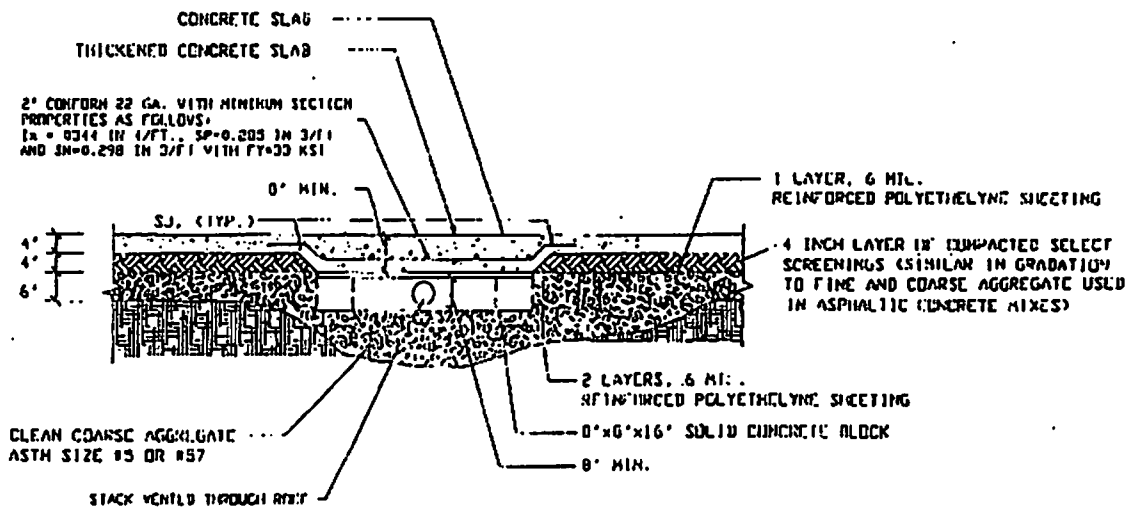

Figure 2: A schematic diagram of the foundation details of the passive radon control system.

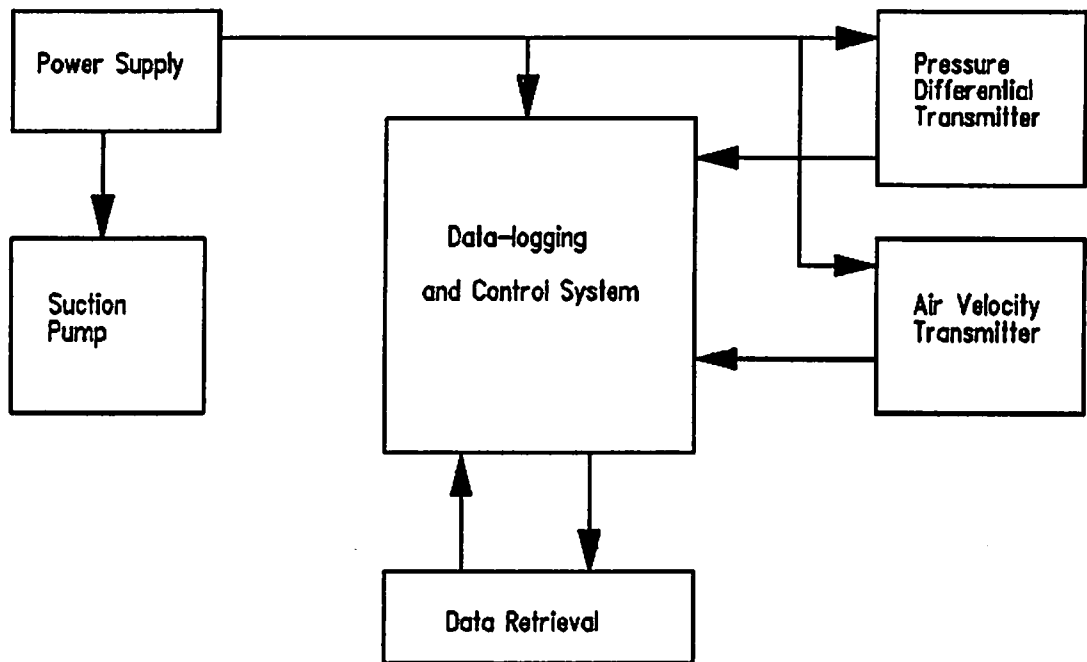

Figure 3: A schematic diagram of the data-logging and control assembly used at the BRDS.

## RESULTS AND DISCUSSION

The average soil gas concentration was found to be 2576 pCi/l discarding the highest and lowest measurements (10,102 and 835 pCi/l, respectively). This figure is not very high compared to some other sites tested in Alachua County with concentrations four to ten times this figure. Nevertheless, it was high enough to warrant the preventive measure of installing a passive radon control system in the building.

The air handling system in the BRDF was designed to provide 100% fresh air circulation in the building in consideration of its biological laboratories. Initial indoor radon concentration measurements were first conducted immediately after completion of the building construction, but before the building was occupied. Under the latter condition, screening performed by the UF's Environmental Health and Safety Division in 16 indoor locations indicated radon concentrations ranged from 0.5 to 3.8 pCi/l with an average of 1.4 pCi/l using E-PERMs. Independent but simultaneous measurements were performed by UF's Department of Nuclear Engineering Sciences using E-PERMs, Honeywell and Pylon devices resulted in an average indoor radon concentration of 1.9 pCi/l, and illustrated a strong diurnal cycle in which the peak radon concentrations routinely exceeded 4 pCi/l.

Upon occupation of the building and with the air handling system fully operational; continuous monitoring of indoor radon concentrations, air flow out of the system, and pressure differentials were subsequently made under different operational configurations of the PRCS. Indoor radon concentrations were averaged in time and location for each of the testing configurations to provide an overall measure for comparison among these configurations. Table 1 summarizes the results of indoor radon concentrations, along with the other measured parameters, for each of the testing configurations. Although, testing was designed to include the installation of temporary fans on each of the PRCS vents and interchanges of the configuration, only tests with fan on one vent (the south wing vent) were successfully performed due to the lack of control over building occupants who kept disconnecting the electricity to the fan installed on the north wing vent of the system. Figure 4 shows a plot of the temporal and spatially averaged indoor radon concentrations for the tested PRCS configurations.

The testing configuration that best represents the indoor radon concentrations corresponds to the case if no passive radon control system had been included is with the vent stacks on both the south and north wings capped. In this case the average indoor radon concentrations exceeded 4 pCi/l, significantly in some areas, even though passive barrier features represented by the reinforced polyethylene sheeting were installed in the building. Although barriers were implemented, it is apparent that reworking of the plumbing and electrical utilities resulted in a significant amount of damage to the polyethylene sheeting and a subsequent loss of effectiveness. It has been observed that because portions of the slab in large buildings are frequently opened, for various reasons, both during construction and over the lifetime of the structure, passive barriers cannot be counted on to provide consistent barriers to radon entry in large buildings.

As seen in Table 1, average indoor radon concentration dropped to 2.7 pCi/l when both of the PRCS vents were opened. This is a reduction of approximately 36% of the concentrations when both system vents were capped. When concentrations in a large buildings are marginal, a passive radon control system can, therefore, provide reasonable reduction to indoor radon to below the recommended action level. This is attributed to the venting of the extended gravel bed underneath the building slab, which provides for a significant pressure normalization in the overall bed void volume, particularly for building of this size and type of structure, and therefore reducing pressure differentials responsible for driving radon-rich soil gas from the sub-structure area into the indoor. This observation supports the theoretical concept of the sub-slab pressure break system that was previously designed for residential structures (Hintenlang 1992); based on experimental results obtained from the UF radon research house, a full scale heavily instrumented residential structure utilized for radon research (Hintenlang and Al-Ahmady, 1992; Al-Ahmady 1992).

Pressure normalization in the PRCS void system was very consistent with the capping and uncapping of the vents throughout the experiments. The gravel bed system pressure was less normalized with only one vent open to the atmosphere, resulting in collectively larger driving forces for radon entry and higher indoor radon

Table 1: Summary of results for testing performed in the BRDF under different passive and active operational configurations of the building passive radon control system.

Test Configuration Description	I.D.	Maximum Air Velocity (m/s)	Average Volumetric Flow Rate (cfm)	Differential Pressure (Pa)	Average Indoor Radon Con. (pCi/l)
<b>Passive Operational Conditions</b>					
South and north wing vents uncapped	1	0.45	3.90	n/a	2.72
North wing vent capped, and south wing vent uncapped	2	0.41	3.56	n/a	3.54
South wing vent capped, and north wing vent uncapped	3	0.38	3.31	n/a	3.56
South and north wing vents capped	4	n/a	n/a	n/a	4.31
<b>Active Operational Conditions</b>					
South wing vent pump on, and north wing vent capped	5	6.77	131.30	197.40	1.25
South wing vent pump on, and north wing vent uncapped	6	7.22	139.90	180.90	1.52

concentration. In testing configurations with the south wing vent capped and the north wing vent uncapped, and vice versa (test I.D. 2 & 3), average indoor radon concentrations were 3.56 and 3.54 pCi/l, respectively. Although, the overall concentrations in the building are below 4 pCi/l with only one vent opened, some areas of the building exhibited concentrations greater than 4 pCi/l in both configurations.

Under the passive operational configurations, measurable air flow rates ranging from 3.9 to 3.3 cfm were detected for test configurations 1 to 3, respectively. The average air flow rate out of the south wing vent is slightly higher than the north wing vent, when the other vent is capped. This is attributed to the larger thermal plume generated from higher stack due to the longer south vent pipe. Temperature stratification profile in the south wing vent is larger and therefore larger natural convection occurs contributing to the higher average air flow rate observed. Continuous measurement of air flow out of the vents indicated a flow pattern that varies with a diurnal cycle throughout the day but with no reversed flow into the system. This is an important parameter for consideration in PRCS design. If the system reversed flow, a reverse function may be developed affecting the system operation in relation with soil-gas driving forces. The latter behavior depends on weather patterns in the area, temperature distributions across the sub-structure area, and the system features. If reversed flow exists for a considerable portion of the day, a directional flow control may be necessary to be installed on the system vent.

Discrete and continuous flow measurements were made during the active operational testing of the system. The average flow rate out of the south wing vent was approximately 131 and 140 cfm with the north wing vent capped and uncapped, respectively. Although the two system vents are spatially well separated, a communication of short-circuiting may occur between the two vents. Given the large fraction of void space in the system medium (gravel bed), the increased averaged air flow rate resulted from uncapping the north wing vent may be attributed to a partial redistribution of pressure field extension resulted from air short-circuiting. This is also evidence by the reduction in differential pressure across the suction pump by approximately 17 pascals (test I.D. 5 & 6). However, for the current PRCS features, this air circling is minimal under passive operating conditions as evident by the passive testing conditions performed interchangeably on both vents while the other vent capped and uncapped.

Averaged indoor radon concentrations were 1.25 and 1.52 for the active testing configurations 5 and 6, respectively. Larger reductions in radon concentration were achieved with the north wing vent capped, which provided a larger pressure field extension in the system gravel bed. The level of indoor radon concentration with the north wing vent left open is satisfactory (1.52 pCi/l) indicating the effect of the limited communication between the system vents. Although, fan installation on both vents at the same time was not manageable to be performed and tested, it is expected that the average indoor radon concentration will drop to below 1 pCi/l if such a configuration is applied.

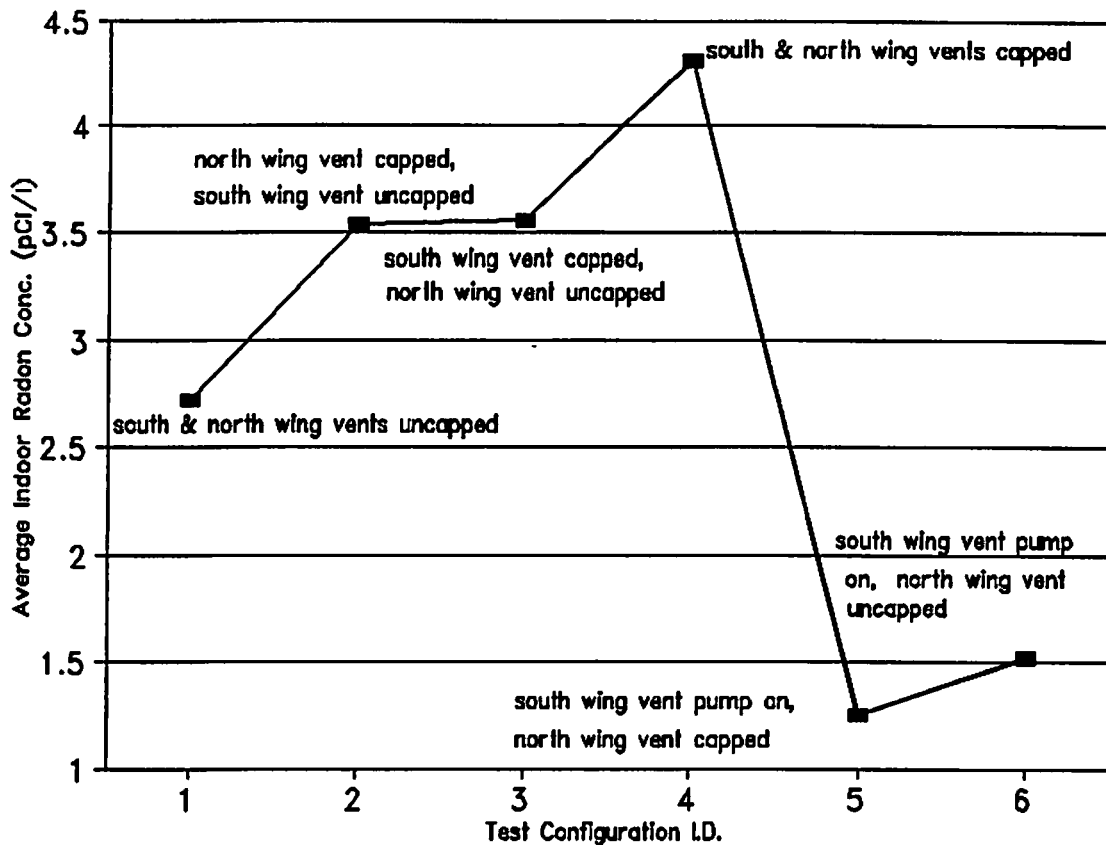

Figure 4: The average indoor radon concentrations as a function of the PRCS active and passive operational configuration at the UF Biotechnology Research and Development Facility.

### CONCLUSIONS

A passive radon control system (PRCS) was incorporated into the foundation of an approximately 35,000 sq. ft. large building in Alachua County based on initial testing of in-situ soil-gas concentration testing performed prior to construction. Results from such tests analyzed with available information about radon potential and other soil and geographical data in the area can be used as the bases for a decision to incorporate radon control in large buildings. Incorporation of radon control systems during construction may result in significant cost saving over a similar system installed after construction. The PRCS may be designed as an extended gravel bed underneath the structure slab with polyethylene sheeting to provide integrity over non-radial air flow movements across the upper and lower surfaces of the system porous medium, which is vented through pipes extended from the bed through the building roof. Such design provides the flexibility to incorporate active suction system that can be mounted on the vent stack if needed after completion and testing of the building. A careful design criteria is needed to optimize the

system design, operation, and consequently realize saving in the system capital investment. Data supporting such insurance is currently limited and further research in the area is needed. It is important to consider the air flow direction from the system vents and to incorporate reverse flow control in vent pipes if needed. The latter consideration must be made through analysis of the system features, structure features, and weather patterns in the area. It has been demonstrated that a pressure break provided by the system vent through the process of normalizing the system medium pressure with changes in barometric pressure is essential for satisfactory performance of such a PRCS. It has been observed that because portions of the slab in large buildings are frequently opened, for various reasons, both during construction and over the life time of the structure passive barriers alone can not be counted on to provide consisted barrier to radon entry. The PRCS incorporated into the building examined in this research was capable of reducing average indoor radon concentrations to below 4 pCi/l when both system vents are opened to atmosphere.

## REFERENCES

Al-Ahmady, K.K.; Klein, W.G.; Eldredge, C.P.; Phillips, D.M.; Gilley, N.M. "Study of the Reported Indoor Radon Measurement Results for Residential Structures and Large Buildings in Florida", In Proceedings of the 1996 International Radon Symposium, Haines City, Florida, September 29- October 2; 1996.

Al-Ahmady, K.K. "Measurements and Theoretical Modeling of A Naturally Occurring  $^{222}\text{Rn}$  Entry Cycle For Structures Built Over Low Permeability Soils", Master of Engineering Thesis, University of Florida, Gainesville, FL; 1992.

Hintenlang, D.E. "Passive Pressure-Break for Slab-on-Grade Structures", Summary of Award Winners, the 1992 Innovative Radon Mitigation Design Competition, the Association of Energy Engineers and the U.S. Environmental Protection Agency; pp. 11-13; 1992.

Hintenlang, D.E. and Al-Ahmady, K.K. "Pressure Differentials For Radon Entry Coupled to Periodic Atmospheric Pressure Variations", *Indoor Air*, Vol. 2, No. 12, pp. 208-215; 1992.

Nagda, N.L.; Koontz, M.D.; Fortmann, R.C.; Schoenborn, W.A.; Mehegan, L.L. "Florida Statewide Radiation Study", Geomet Report Number IE-1808, Geomet Technologies, Inc.; 1989.

Nielson, K.K.; Holt, R.B.; Rogers, V.C. "Development of A Radon Protection Map for Large Buildings in Florida", EPA-600/R-96-028; 1996.

United States Environmental Protection Agency (USEPA) "EPA's Map of Radon Zones-Florida", EPA 402-R-93-029; 1993.

### *Acknowledgment*

This work is supported by the Florida Department of Community Affairs under Contract 95RD-74-13-00-22-002.