

## **EFFECTS OF HUMAN BEHAVIOR ON INHALATION EXPOSURE TO RADON VOLATILIZED FROM DOMESTIC WATER USES**

Harry E. Rector and Charles R. Wilkes  
GEOMET Technologies, Inc.  
Germantown, MD

Nicholas J. Giardino  
Armstrong Laboratory, Office of Environmental Medicine and Health, United States Air Force  
Brooks AFB, TX

### **ABSTRACT**

Volatilization from domestic water uses can produce significant indoor radon concentrations in areas affected by radium-bearing aquifers. While radon levels in the water supply play an important role in determining exposure, the ultimate magnitude of such exposures also depends on human activities to operate various components of the water system and to situate members of the household in the scenario. In the work reported here, human activity data was utilized to establish spatial and temporal patterns of domestic water use and to identify locations of household members throughout a typical daily schedule. The activity data along with appliance-specific radon release rates, airflow data, and physical property data was applied to an indoor air quality model to evaluate patterns of concentration and exposure arising from typical scenarios. Indoor concentrations of radon and radon decay products in a sample home and resulting inhalation dose were computed for specific individuals and families of individuals to isolate the effects of direct exposure (i.e., occupant exposed to radon from self-directed water use) versus co-exposure (i.e., occupant exposed to radon from water use directed by someone else in the household). It was found that the shower delivers the potential dose at the highest rate.

### **INTRODUCTION**

Volatilization from domestic water uses can produce significant indoor radon concentrations in areas affected by radium-bearing aquifers. While radon levels in the water supply play an important role in determining exposure, the ultimate magnitude of such exposures also depends on human activities to operate components of the water system and to situate members of the household in the scenario. In the work reported here, human activity data was utilized to establish spatial and temporal patterns of domestic water use and to identify locations of household members throughout a typical daily schedule. The activity data along with appliance-specific radon release rates, airflow data, and physical property data was applied to an indoor air quality model to evaluate patterns of concentration and exposure arising from typical scenarios. Indoor concentrations of radon and radon decay products in a sample home and resulting inhalation dose were computed for specific individuals and families of individuals to isolate the effects of direct exposure (i.e., occupant exposed to radon from self-directed water use) versus co-exposure (i.e., occupant exposed to radon from water use directed by someone else in the household). It was found that the shower delivers the potential dose at the highest rate.

### **MODEL FRAMEWORK**

The indoor air quality/exposure model used in this study is based on earlier work to evaluate the role of human activity patterns and other indoor environment factors in determining inhalation exposure to a variety of chemicals volatilized from domestic and municipal water supplies (Wilkes et al., 1992). Under support from the U.S. Air Force, the model framework is undergoing expansion to potentially incorporate comprehensive depictions of source processes, reversible/irreversible sinks, and pharmacokinetics.

The model implements a deterministic, pollutant mass-balance calculation for indoor air pollutant concentrations. The building is represented by a collection of well-mixed compartments interconnected by flow elements. The compartments are typically determined by physical boundaries in the building. The mass-balance for compartment  $i$  is given by:

$$\frac{dC_i}{dt} = \sum_j C_j \frac{Q_{ij}}{V_i} - \sum_j C_i \frac{Q_{ji}}{V_i} + \sum \frac{S_i}{V_i} - C_i \sum \lambda_c \quad (1)$$

where  $i$  and  $j$  are compartment numbers,  $V_i$  is the volume in compartment  $i$ ,  $C_i$  is the air concentration in compartment  $i$ ,  $t$  is time,  $Q_{ij}$  is the flowrate from compartment  $i$  to compartment  $j$ , and  $\lambda_c$  is one or more characteristic first-order processes (e.g., radioactive decay, deposition). The air contaminants are transported between compartments by the air flows. The air flows may be constant, based on short-term conditions of interest. The air flows may also be variable, responding to changing conditions in the model, such as the opening and closing of windows or doors, or operation of exhaust fans, or responding to changing environmental conditions, such as the ambient wind speed or temperature. Equation 1 is solved for each compartment using the fourth-order Runge-Kutta method (Press *et al.*, 1988) for temporal integration.

Volatilization of radon from the water supply during a given water use is calculated from two-film gas transfer theory (see Giardino *et al.*, 1990):

$$S = f_v F_w \left( C_w - C_A / H \right) \quad (2)$$

where  $S$  is the volatilization source term ( $\text{pCi min}^{-1}$ ),  $C_A$  is the radon concentration in the air ( $\text{pCi L}^{-1}$ ),  $C_w$  is the radon concentration in the water prior to volatilization ( $\text{pCi L}^{-1}$ ),  $H$  is the dimensionless Henry's constant (the equilibrium ratio,  $C_A/C_w$ ),  $f_v$  is the dimensionless mass-transfer coefficient (equal to the fractional volatilization when  $C_A$  is zero), and  $F_w$  is the flowrate of the water ( $\text{L min}^{-1}$ ). Each of the process parameters is assumed constant for a specific water use. The model solves for the relevant air concentration ( $C_A$ ) at each time step. The mass transfer coefficient is a function of the characteristics of the volatilizing species and the water use such as the drop size distribution, residence time, flowrate, and water temperature. The relevant chemical characteristics that affect volatilization include the solubility and vapor pressure, which determine  $H$  and diffusion properties. Where appropriate, the effect of volatilization from the pool of water around the drain is also included in the source parameterization.

A single-story, five-room house (Figure 1) was defined to provide a realistic (though not necessarily representative) basis for modeling scenarios. The air flow balance provides for an air exchange rate of 0.5 air exchanges per hour; which corresponds to current estimates of the national average (Koontz and Rector, 1995). Separate air flow regimes were defined to incorporate effects of closing the bathroom door and to allow for operation of the bath exhaust fan while the door was closed. Deposition of radon progeny was described using a simple first-order removal term ( $1.5 \text{ h}^{-1}$ ) derived from experimental work in research houses (Rector *et al.* 1985). For these model runs, the water supply was assigned a radon concentration of  $10,000 \text{ pCi L}^{-1}$ . Contributions from soil gas entry, emanation from building materials, and outdoor air concentrations were arbitrarily set to zero in order to isolate the effects of the water supply.

The values for the volatilization mass-transfer coefficients presented in Table 1 are based on qualitative estimates of the residence time in which the water is in contact with the surrounding air as well as values reported in the literature for radon volatilization (see, for example Giardino and Hageman 1996, Wilkes *et al.* 1996, Nazaroff *et al.* 1988). The two different values for Henry's constant are for hot ( $40^\circ \text{C}$ ) and cold ( $25^\circ \text{C}$ ) water uses. The volume, flowrate, duration, and frequency data for water consumption used as input for the model have been derived from a U.S.

Department of Housing and Urban Development survey of 200 households (U.S.DHUD, 1984; Marshall, 1990. Each event uses the average amount of water for that event type reported in the survey, but the number of events have been adjusted to the nearest whole number. Volatilization from the toilet was parameterized separately for short term effects of flushing and "standby" losses between uses. A two minute burst representing the turbulent flow conditions that occur during the flush utilizes half of the total water volume delivered for each flush. The remaining volume was converted to a continuous flow spread throughout the day to represent the volatilization from the water standing in the bowl and tank between flushes.

Activity patterns were defined for a hypothetical family consisting of two adults and one child (Figure 2). Adult 1 works outside of the home, and is away between 7:45 am and 5:30 pm. Adult 2 has primary child care responsibility, and performs associated tasks as well as other household tasks. Adult 2 and the child are home for the majority of the day. The "standard day" arising from the source/activity scenario was modeled for two consecutive days to establish carry-through from one day to the next. Analysis and interpretation focused on the second 24 hour period.

## RESULTS AND DISCUSSION

Large temporal and spatial variations occur in the radon profiles of the modeled home. As shown in Figure 3, radon concentrations in a given source room rise quickly but elevated levels do not persist for long after the water use ends. Highest concentrations (approaching  $60 \text{ pCi L}^{-1}$ ) were produced in the shower and in the bathroom (approaching  $20 \text{ pCi L}^{-1}$ ). This impact was largely confined to the bathroom, however, by keeping the door closed and operating the exhaust fan. Laundry operation and, to a lesser extent, water use in the kitchen, on the other hand, raised concentrations throughout the house.

Room-to-room variations are somewhat smaller for 24-hour average radon concentrations (Table 2), varying by about a factor of six from the shower ( $4.1 \text{ pCi L}^{-1}$ ) to the living room and bedroom areas ( $0.7 \text{ pCi L}^{-1}$ ). The volume-weighted average radon concentration for this scenario was  $1.1 \text{ pCi L}^{-1}$ , corresponding well with generally accepted rules-of-thumb for the impact of waterborne radon. Radon progeny levels showed less room-to-room variations, ranging from 0.003 WL in the living room and bedroom areas to 0.01 WL in the bathroom.

Average concentrations in locations that would be selected for standard monitoring were significantly lower than the averages accumulated by family members as they moved from place to place. The time-averaged radon exposure for Adult 2 is twice that implied by concentrations in the living room. Time-averaged exposure to radon progeny, on the other hand is only about 10 percent higher than 24-hour averages in the living room would suggest; this is probably due to the relatively slow ingrowth of radon progeny and the abbreviated occupancy. Exposures for the child or for Adult 1 are significantly smaller. Adult 1 spends just over 14 hours in the home and, except for showering, spends relatively little time in the proximity of waterborne sources. Adult 2, on the other hand, spends nearly 20 hours in the in the home and performs most of the water-using tasks, such as the laundry. The equivalent exposure of the child is lower even though the time spent in the house is the same as for Adult 2. A large share of the difference is due to the morning shower taken by Adult 2. Also, the effect of Adult 2 taking a shower immediately after Adult 1 has taken one can be seen in Figure 3. Even though both adults take showers of equal length, Adult 2 is exposed to significantly higher concentrations due to residual concentrations from the first shower. The showering activity accounts for approximately 25 percent of the radon exposure while occupying only about 2 percent of the time spent in the home.

## CONCLUSIONS

Physical characteristics of radon volatilization from water use and room-to-room transport, as well as human activity and locations of sources are essential elements of residential exposure in regions where water supplies pose concerns. In addition, it is necessary to consider location and water use characteristics of the occupants when evaluating the effect of a contaminated water supply on inhalation exposure.

## REFERENCES

Giardino, N.J., and Hageman, J.P. (1996) "Pilot Study of Radon Volatilization from Showers with Implications for Dose." *Environmental Science & Technology*. vol. 30, no. 4, pp 1242-44.

Giardino N.J., Gumerman E., Andelman J.B., Wilkes C.R., and Small M.J. (1990) Real-Time Air Measurements of Trichloroethylene in Domestic Bathrooms using Contaminated Water. *Proceedings -- The Fifth International Conference on Indoor Air Quality and Climate*, Toronto, July 1990, Vol. 2 p707-712.

Koontz, M.D., and Rector, H.E. (1995). Estimation of Distributions for Residential Air Exchange Rates. GEOMET Report No. IE-2603. Prepared for U.S. Environmental Protection Agency, Office of Pollution Prevention and Toxics, Washington, D.C.

Marshall J. (1990) *In-House Water Use and Human Activity Patterns: Input Data for MAVRIQ*. Master's Thesis, Graduate School of Public Health, University of Pittsburgh, Pittsburgh PA, 15261.

Press W.H., Flannery B.P., Teukolsky S.A., and Vetterling W.T. (1988) *Numerical Recipes in C*, Cambridge University Press, New York, NY.

Rector, H.E., Koontz, M.D., Cade, D.R., and Nagda, N.L. (1985). Impact of Energy Conservation Measures on Radon and Radon Progeny Concentrations: A Controlled Study. *ASHRAE Transactions*, Vol 91, Part 2, pp 1954-62.

U.S. Department of Housing and Urban Development (1984) *Residential Water Conservation Projects*. Contract H-5230.

Wilkes, C.R., Small, M.J., Davidson, C.I., and Andelman, J.B. (1996). "Modeling The Effects Of Water Usage And Co Behavior On Inhalation Exposures To Contaminants Volatilized From Household Water." accepted for publication by the *Journal of Exposure Analysis and Environmental Epidemiology*.

Wilkes, C.R., Small, M.J., Andelman, J.B., Giardino, N.J., and Marshall, J. (1992). "Inhalation exposure model for volatile chemicals from indoor uses of water." *Atmospheric Environment*. 26A(12): 2227-2236.

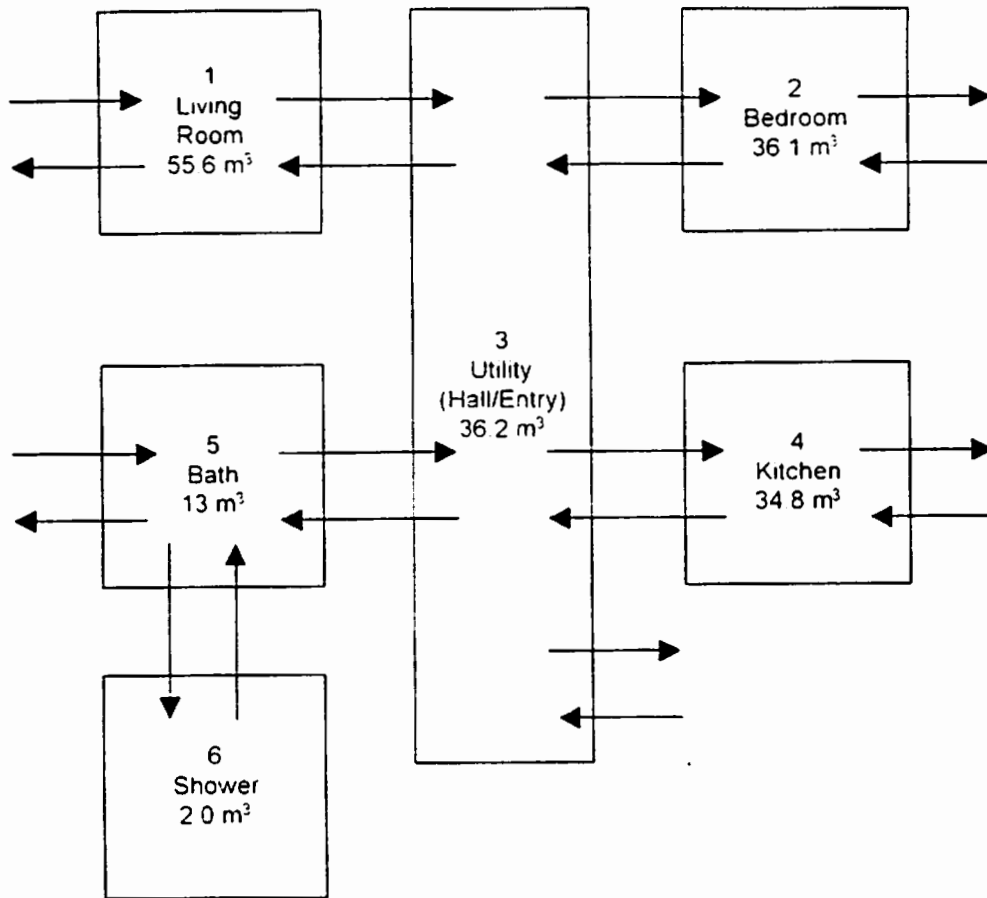

**Exfiltration ( $\text{m}^3 \text{h}^{-1}$ )**

$Q_{10} = 14.1$   
 $Q_{20} = 9.8$   
 $Q_{30} = 36.2$   
 $Q_{40} = 36.3$   
 $Q_{50} = 2.4 [44.9]^*$   
 $Q_{60} = 0.0$

**Infiltration ( $\text{m}^3 \text{h}^{-1}$ )**

$Q_{01} = 28.7$   
 $Q_{02} = 20.4$   
 $Q_{03} = 25.0 [67.5]^*$   
 $Q_{04} = 13.5$   
 $Q_{05} = 1.2$   
 $Q_{06} = 0.0$

**Interzonal Airflows ( $\text{m}^3 \text{h}^{-1}$ )**

$Q_{13} = 67.5$   
 $Q_{31} = 52.9$   
 $Q_{23} = 41.1$   
 $Q_{32} = 30.5$   
 $Q_{43} = 27.2$   
 $Q_{34} = 50.0$   
 $Q_{53} = 15.1 [4.2]^*$   
 $Q_{35} = 16.3 [47.9]^*$   
 $Q_{56} = 25.0$   
 $Q_{65} = 25.0$

\* Bracketed values denote flows while bathroom door is closed and exhaust fan operates

Figure 1. Flow Balance for Model Scenarios.

Table 1 Mass-Transfer Coefficients for Modeled Sources

Water Source	Flowrate (L min <sup>-1</sup> )	Mean Event Duration (min per event)	Event Frequency (Events per day)	Volatilization Coefficient <i>f<sub>v</sub></i>	Henry's Law Constant <i>H</i>
Shower	7.95	7.7	2	0.85	0.87
Bath	15.80	30.0	1	0.70	0.87
Toilet Flush	4.40	2.0	3	1.00	0.5
Standby		Continuous		0.90	0.5
Dishwasher	0.60	30.0	1	0.90	0.87
Clothes Washer	4.17	30.0	1	0.90	0.87
Kitchen Faucet	5.28	10.0	3	0.5	0.5
Bathroom Faucet	5.28	5.0	5	0.5	0.5
Laundry Faucet	5.28	5.0	1	0.5	0.5

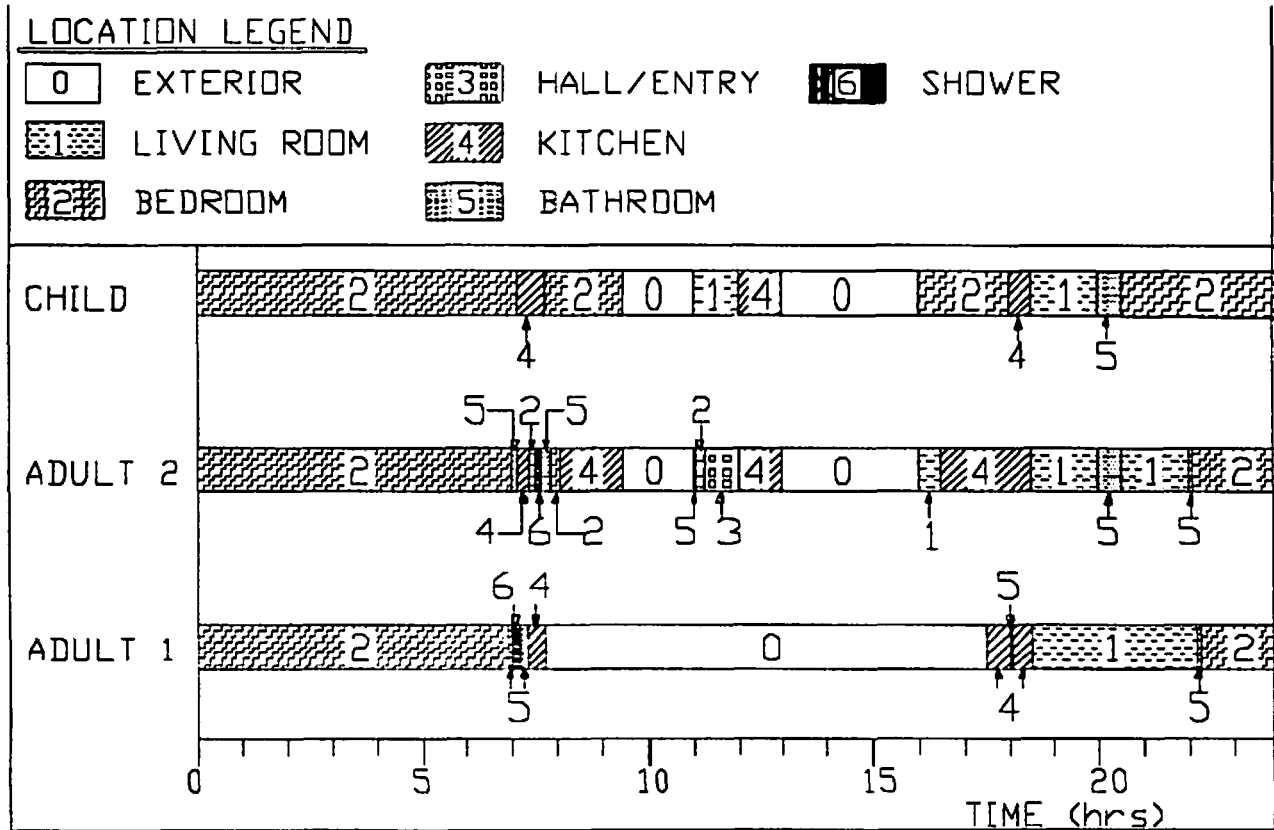

Figure 2. Daily Household Activity Patterns.

Table 2. Summary of Model Results

Modeled Concentrations (24-hour Average)						
	Living Room	Bedroom	Utility	Kitchen	Bath	Shower
Radon (pCiL <sup>-1</sup> )	0.7	0.7	1.1	1.1	3.4	4.1
Radon Progeny (WL x 100)	0.29	0.26	0.38	0.44	1.05	0.67
Modeled Exposures (24-hour Average)						
		Adult 1	Adult 2	Child 1		
	Radon (pCiL <sup>-1</sup> )	1.3	1.4	0.8		
	Radon Progeny (WL x 100)	0.18	0.32	0.22		

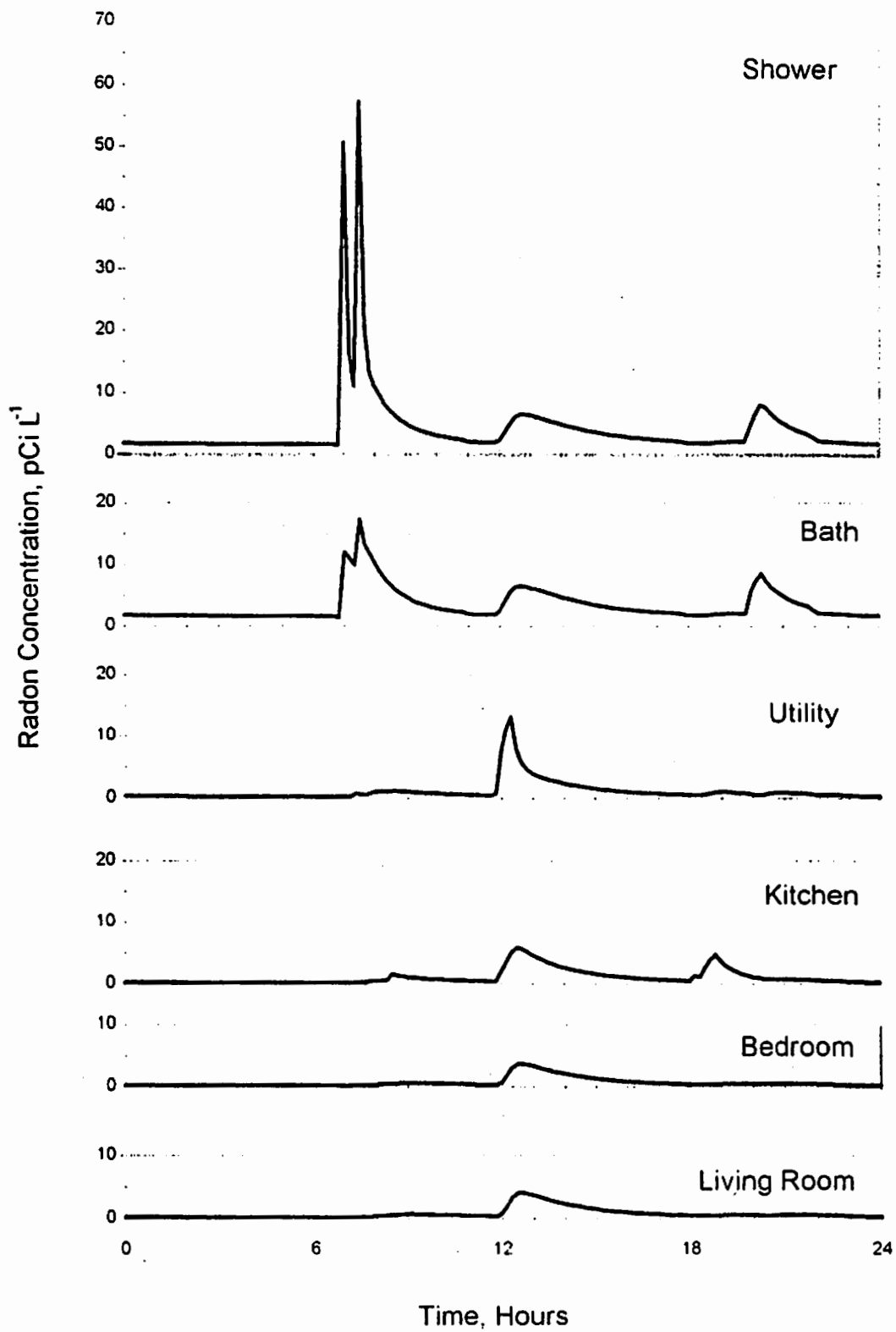

Figure 3. Modeled Radon Concentrations.