

## **A COMPUTER PROGRAM FOR ASD SYSTEM DESIGN APPLICATIONS IN LARGE BUILDING RADON MITIGATION**

Kaiss K. Al-Ahmady and David E. Hintenlang  
Department of Nuclear Engineering Sciences, University of Florida  
Gainesville, FL

### **ABSTRACT**

Many practical applications for reducing elevated indoor radon concentrations depends on the utilization of active soil depressurization (ASD) systems such as the Sub-Slab Depressurization system. Applications of these systems for radon mitigation in large structures such as schools, hospitals and commercial offices are significantly more complicated than applications in residential structures due to the complexity and features of large buildings. A computer program has been developed to aid in designing and selecting appropriate ASD systems for large building radon mitigation practices. The program is based on mathematical modeling of the pressure distribution in the sub-structure system that utilizes solutions of the continuity and pressure equations in porous media. The model predicts the pressure field extension (PFE) developed by forced pressure point(s) applied to the sub-structure system. The program utilizes finite difference solutions to visualize spatial dependency of PFE that might be generated by ASD system design and configurations. The program has been developed using an extensive graphical user interface to facilitate easy utilization by ASD designer and radon mitigators. The program is capable of providing 3D PFE maps and system efficiency assessment for large structures incorporating different features such as slab size and shape; suction mats size, shape, and orientation; grade beams; and structure foundation. The program provides a significant tool for the design and application of ASD systems for radon mitigators.

### **INTRODUCTION**

Most practical applications for reducing elevated indoor radon concentrations depend on the utilization of Active Soil Ventilation and Depressurization (ASV&D) systems. Although other methods have been developed to reduce and control elevated indoor radon concentrations, ASV&D systems are by far the most widely used and commercially available systems. The principle concept behind the operation of ASV&D systems is simple and it depends on creating a low pressure area underneath the building structure. Radon-rich soil gas, the principle source of elevated indoor radon concentrations, may then be forced into the low pressure area and exhausted outdoors instead of sweeping into the building through openings between the sub-structure area and the building interior.

Four system designs (Drain Tile Ventilation, Block-Wall Ventilation, Isolation and Venting of Area Sources, and Sub-Slab Depressurization) can be distinguished based on the features of building structure (EPA 1988). Sub-Slab Depressurization (SSD) systems are the most effective and widely used ASV&V system. Due to their wide usage, simulation of their operation incorporating different structure features represents an important and useful tool serving radon education, control, and mitigation purposes. Simulation capabilities are particularly critical in analyzing the Pressure Field Extension (PFE) developed by the SSD system operation in different structures and with many design options. In addition, it is critical for understanding the interaction between the PFE developed by an SSD system and the pressure differences across the structure slab which is the major radon driven forces from the sub-structure area into the interior.

During SSD system operation depressurization is established under the slab by drawing suction on pipes installed into the soil/fill/aggregate area. The primary depressurization point is usually extended to cover larger

volumes under the slab using highly permeable materials such as pit and matting media. These media are connected to the end of the suction tube to provide better pressure field distribution and prevent blocking of the suction tube. The success of the SSD system is dependent on the extent to which negative pressure can be maintained under the slab area. This parameter is directly dependent on the pressure field extension developed by the system.

Modeling of the SSD system operation for residential structures has been developed. Simulation approaches for SSD operation in residential structures have been started from introductory considerations (Hintenlang and Furman 1990, Hintenlang and Barber 1991) and extended to more sophisticated modeling utilizing three dimensional spatial solutions for equations governing the generation of PFE in a soil system developed by SSD system operation (Hintenlang 1993). Although simulation approaches for SSD modeling and system design in large structures such as hospitals, schools, and commercial buildings are the same in principle, applications for such activities are significantly more complicated due to the complexity of large structures compared to residential ones. Mitigation practices and documentation regarding reduction of indoor radon concentrations using SSD systems or any other radon mitigation systems in large structures are profoundly limited when they are compared with the practices for residential structures. Furthermore, in addition to the complexity of large structures which require better SSD system design, the cost of installing radon mitigation systems in large structures is much more expensive which suggests a strong need to use a simulation approach that helps to understand driving forces, analyzes system performance, and produces a suitable system design prior to installation.

A mathematical modeling and initial simulation approach for SSD systems dealing with radon mitigation applications in large buildings has been developed by Al-Ahmady and Hintenlang (1994). They developed a model that is based on the solution of the soil gas mass continuity equation and pressure equation in porous media to predict the PFE developed by an SSD system. A finite difference solution was provided to transfer the model into a programmable computer format. In this work, extension to the 1994 model was developed to provide an extensive Graphical User Interface (GUI) for the purpose of providing educational and training tools for students interested in the radon subject and for mitigators interested in installing SSD systems in large structures. Furthermore, the new model provides an extended tool that allows to set options to perform comparisons between the predicted PFE developed by a particular system design and the experimental set of pressure differentials across the structure slab.

## MATHEMATICAL CONSIDERATIONS

Treatment of the mathematical framework governing the pressure gradient in porous media for the purpose of modeling SSD systems was given in a paper by Al-Ahmady and Hintenlang (1994). In this section, only outlines necessary to clarify the concepts supporting the SSD simulation is discussed. Further treatment can be obtained from the paper above. Since only the spatial dependency of the pressure gradient needs to be considered in this application, the treatment can be significantly simplified. By neglecting the gravity effect and utilizing cartesian coordinates, the net mass flows leaving a differential volume  $dV$  in three dimensions can be expressed by the change of the fluid velocity in all directions,

$$Q = - \int \rho \left( \frac{\delta v}{\delta x} + \frac{\delta v}{\delta y} + \frac{\delta v}{\delta z} \right) dx dy dz dt \quad (1)$$

where  $\rho$  is the density of soil gas ( $\text{kg}/\text{m}^3$ ) and is assumed to be independent of the gas position,  $Q$  is the time-integrated soil gas net mass (kg) flow in all directions,  $v$  is the directional fluid velocity, and  $(dx, dy, dz)$  or  $dV$  is the differential volume in  $\text{m}^3$ .

In cartesian coordinates a simple differential volume is a cube of six equal faces. Equation 1 expresses the net flow of the gas in the differential volume, that is, it compensates for the inward gas mass flow into the

volume and the outward mass flow out of the volume. The negative sign in front of Equation 1 is therefore indicating net flow out of the six faces of  $dV$ . Applying the mass conservation principle, the accumulation of mass in  $dV$  must equal the net mass flow out of the volume. Since the steady state condition was considered and integration over the time introduced a constant to Equation 1, the mass accumulation in the differential volume must equal to zero, then

$$\frac{\delta v_x}{\delta x} + \frac{\delta v_y}{\delta y} + \frac{\delta v_z}{\delta z} = 0 \quad (2)$$

To represent the pressure under the slab for the purpose of estimating the PFE, Darcy's law can be employed to relate the directional velocity with the pressure gradient as,

$$v = \left( \frac{k}{\mu} \right) \cdot \nabla P \quad (3)$$

where  $k$  is the intrinsic soil permeability ( $m^2$ ),  $\mu$  is the soil gas viscosity ( $kg/s.m$ ), and  $\nabla P$  (Pa) is the pressure gradient. If the directional velocity components in Equation 2 are substituted by the equivalent form Equation 3, then

$$\left( \frac{\delta^2}{\delta x^2} + \frac{\delta^2}{\delta y^2} + \frac{\delta^2}{\delta z^2} \right) \cdot P = \nabla^2 P = 0 \quad (4)$$

The 3D linear partial differential equation above must be converted into algebraic equations suitable for programming. Such equations, along with boundary conditions, can be simultaneously solved to predict the PFE developed by SSD systems for different structure features and configurations. By utilizing a finite difference technique and employing a control volume approach, the second derivative in the x-direction in Equation 4 can be converted into the following linear equation,

$$\frac{\delta^2 P}{\delta x^2} = \frac{1}{h^2} [ P(x+h, y, z) - 2P(x, y, z) + P(x-h, y, z) ] \quad (5)$$

where  $h$  is the distance between the centers of two control volumes in the x-direction. Utilizing this simple treatment, the soil system volume which represents the medium of solution is divided into a number of non-overlapping equally spaced control volumes. Each center of a control volume is represented as a node in the soil system and can be located by its coordinate  $(x, y, z)$  values. The value of the dependent variable ( $P$ ) is calculated in the center of the control volume and assumed to stay constant over that volume. Since equally spaced control volumes are employed, the distances between two centers in the y-direction and two centers in the z-direction are the same as in the x-direction and equal to  $h$ . Similar to Equation 5, two linear equations can be generated for the second and third derivative terms in Equation 4 as the following,

$$\begin{aligned} \frac{\delta^2 P}{\delta y^2} &= \frac{1}{h^2} [ P(x, y+h, z) - 2P(x, y, z) + P(x, y-h, z) ] \\ \frac{\delta^2 P}{\delta z^2} &= \frac{1}{h^2} [ P(x, y, z+h) - 2P(x, y, z) + P(x, y, z-h) ] \end{aligned} \quad (6)$$

The value of  $P$  can be found as a function of position in the soil system by substituting Equations 5 and

6 into Equation 4,

$$P(x, y, z) = (1/6) [P(x+h, y, z) + P(x, y+h, z) + P(x, y, z+h) + P(x-h, y, z) + P(x, y-h, z) + P(x, y, z-h)] \quad (7)$$

### ALGORITHM DEVELOPMENT

The algorithm is constructed using a set of indices to control the pressure calculations, locate the boundary conditions, and control the iterations. Pressure values are called by the indices  $i, j, k$  that correspond to the coordinates  $x, y, z$ , respectively. A mesh generator is used to develop the node network in the solution volume limited by the slab length, slab width, and a selected soil depth. The number of nodes generated is dependent on the selected space ( $h$ ) between nodes and the solution volume. The indices  $i, j, k$  are used to represent nodes in the  $x, y$ , and  $z$  direction, respectively.

A set of boundary conditions are used to start and control the solution of the pressure field extension in the soil system. Basic boundary conditions applied in the solution are represented by:

- (1) pressures of all nodes start with zero and stay constant (steady state) after the last iteration in the program;
- (2) pressure values for all nodes purposely connected into the suction tube(s) using high permeability materials, such as radon ( $R_n$ ) matting, are constant and equal to the suction pressure;
- (3) nodes located immediately below the slab have only five-face flow instead of six, except for those labeled for suction tube, suction matting, and/or cracks;
- (4) nodes representing control volumes having a side adjacent to a grade beam and the slab have only four flow faces, and nodes representing control volumes of a side adjacent to only a grade beam have five flow faces; and
- (5) pressure nodes located on or beyond the outer surface of the solution volume have pressure values of zero.

The algorithm starts with an initial pressure value of zero at all nodes. The pressure is then updated in one node located at  $i, j, k = 1, 1, 1$  with a positive pressure increment. The value of the increment can be arbitrary selected, however, it must not produce any negative pressure values. After the first iteration, this increment is controlled by the program. In each iteration the pressures in all nodes are calculated and then flow rate calculations are performed into and out of the control volume specified by the boundary conditions. All air flows into the soil system are calculated from the updated pressure values in each iteration and compared with the air flow out of the SSD suction tube(s). When the difference between both flows reaches less than 1%, the iteration stops and the last pressure calculations are transferred into the program output files.

An event-driven logic style of programming was preferred over using the traditional modular programming in order to make extensive use of pull down menus, dialog boxes, touch buttons, and three dimensional panels in an object-oriented program. Microsoft Visual Basic programming language was utilized to develop the code and the graphical user interface (GUI) for Windows environment. The program was compiled as a stand-alone Windows application and is operated as a shell for this environment. Therefore it can be ported to work under any later versions of Windows. Figure 1 illustrates the program introductory screen that appears after activating the executable file from DOS or invoking the program from Program Manager in Windows. This screen represents the program main menu, advances the user to select an activity from the menu, and prompts the user with error

messages and directions throughout program utilization. All dialogues are self-explanatory and they appear through 3D dimensional panels prompting the user to the mouse movements.

A set of floating tool palettes which appears on the main screen was included in the program to facilitate future upgrades. It is also used to accelerate the user's selection of menus by a single click on the appropriate icon, serving users who are familiar with the software. After a selection from the main screen, the user can select to perform an analysis for different slab features and SSD design configurations. SSD design capability includes the ability to specify the shape, size, and orientation with respect to the slab, for one or more suction mats in the system. The size of any mat can be extended from a pit size, that is restricted with the dimensions of the user selection to the 3D analysis element, to the whole slab size. Shapes of the suction mats can be oriented in non-overlapping and/or overlapping layouts by simple specifications to the start and end number elements (point coordinates) of the same indices utilized in specifying the structure slab. This utility enables the user to visualize the PFE developed by the SSD operation and delivered by different mat configurations to meet a required efficiency in preventing elevated indoor radon concentration.

The program was also designed to facilitate the PFE developed by the combination of SSD suction levels and including different structure configurations. The structure slab size and shape, existence of variable length foundation walls, existence of cracks and openings located anywhere in the slab, and existence of grade beam structures, were simulated. Slab features simulations were developed by solving the same finite difference equations utilizing different boundary conditions. The program was structured in a way that allows the incorporation of different structural features by the addition of boundary condition classes. Access to the analysis options is provided under a menu titled Analysis which can be called and used to specify the slab configurations, SSD suction pressure, solution resolution by specifying the required increment size to be used in the solution, and the number of mats, beams, and cracks in the configuration. Figure 2 illustrates the Analysis menu of the program. Once the user selects the Continue push button, subsequent windows will be opened depending on the user selection of the check inputs in the Analysis window. The total number of windows to be opened is equal to the total number of cracks, beams, and mats specified in the Analysis window. These windows are called information windows and there is one window for each mat, beam, and crack. They are specified by the option name (crack, mat, beam), and sequenced by the option number. The information windows prompt the user to input information regarding the size, shape, orientation, and condition of cracks, beams, and suction mats. Figure 3 illustrates information windows for mat and crack, respectively.

Once the user clicks the Next push button in the last information window, all the opened information windows will be closed and the main analysis window will become active on the screen. In this stage, the last window will contain all information and selections previously entered but with a Solve push button appearing in the right corner of the window. After the user clicks this button, the program will start calculating the solution to simulate the PFE developed by the designed SSD system for the given structure configuration. A window will appear on the screen that is simultaneously tracking the number of iterations performed by the program for the whole solution volume. After the solution is completed, another window will inform the user that the analysis has been completed. The program writes output files in ASCII format containing the PFE values arranged with the corresponding spatial location in the soil system. Another output file is also written which supplies a figure of merit reflecting the SSD design with respect to its function in preventing elevated indoor radon concentration. The latter file retains calculated numbers representing the area under the structure slab which is being depressurized due to the SSD operation to a specific amount. This amount can be adjusted by the user following a specific evaluation criteria.

Figure 4 illustrates the program output of a PFE simulation map for a slab-on-grade structure 200x200 feet in size installed with an SSD system, and a mat located at the center of the slab and extending 20 feet each side parallel with the slab side edge. The SSD system provides suction at the tube-mat contact of 400 Pa. The soil is assumed homogenous with constant permeability and the suction pressure is constant in the mat. Figure 5 illustrates a simulation of the PFE generated by an SSD system utilizing two suction mats symmetrically located around the center of a 100x100 ft. slab which are parallel to its edges and is supplied with a suction pressure of 250 Pa. Figure

6 illustrates a simulation of the PFE in the soil system at a distance of two feet under the slab developed by a 200 Pa SSD system comprised of three mats forming a U-shape for a 100x200 ft. slab. The slab was built with grade beam of two feet depth and extended across the slab length parallel to the shorter slab side.

## CONCLUSIONS

Training in the field of radon mitigation utilizing commercially available radon prevention technology can be implemented by developing simulation software capable of visualizing the radon driving forces developed by a mitigation system utilized to prevent elevated indoor radon concentrations. The utilization of such a simulation approach can be used to train students in health physics and other related disciplines, and personnel in other fields such as environmental protection and indoor air quality specialists, radon professionals and mitigation contractors. Three dimensional simulations to radon prevention applications utilizing installation of the Sub-Slab Depressurization (SSD) systems can be developed using a finite difference solution code that solves the pressure field extension generated by SSD systems in the soil system. The code must be designed to adapt different SSD and structure configurations in order to provide simulations for different design options. The simulation program also needs to be developed with a user friendly environment and utilize graphical user interfaces that will better support the purpose of training and education. The Visual Basic programming for Windows environment is well suited for this application. The simulation training program described in this paper can provide extensive evaluation and training for interested parties in designing better SSD systems that prevent elevated indoor radon concentrations. This approach and subsequent software could be effectively used in training and education by providing a visualization and analysis tool for radon prevention applications. The software provides the capability to analyze complicated SSD designs by incorporating system options including mat size, shape, orientation, and suction pressure; and structure features and configurations including slab size and shape, existence of grade beams and cracks, and foundation styles.

## REFERENCES

- Al-Ahmady, K.K. and Hintenlang, D.E. "Modeling of Sub-Slab Depressurization (SSD) Radon Mitigation Systems for Large Structures", Proceedings of the 1994 International Radon Symposium, Atlantic City, New Jersey; 1994:VP1.1-VP1.9.
- Hintenlang, D.E. Reference Manual for RASSMIT Version 2.1: Sub-Slab Depressurization System Design Performance Simulation Program. EPA-600/R-93-027; 1993.
- Hintenlang, D.E.; Barber, J.M. Practical Engineering Analysis for Indoor Radon Mitigation Using Sub-Slab Depressurization Techniques. Radiation Protection Management. 8:63-71; 1991.
- Hintenlang, D.E.; Furman, R.A. Sub-Slab Suction System Design for Low Permeability Soils. Proceedings of the Symposium on Radon and Radon Reduction Technology. EPA/600/9-90/005, III; 1990:V.1-V.4.
- USEPA. Application of Radon Reduction Methods. Air and Energy Engineering Research Laboratory, North Carolina, EPA/625/5-88/024; 1988.

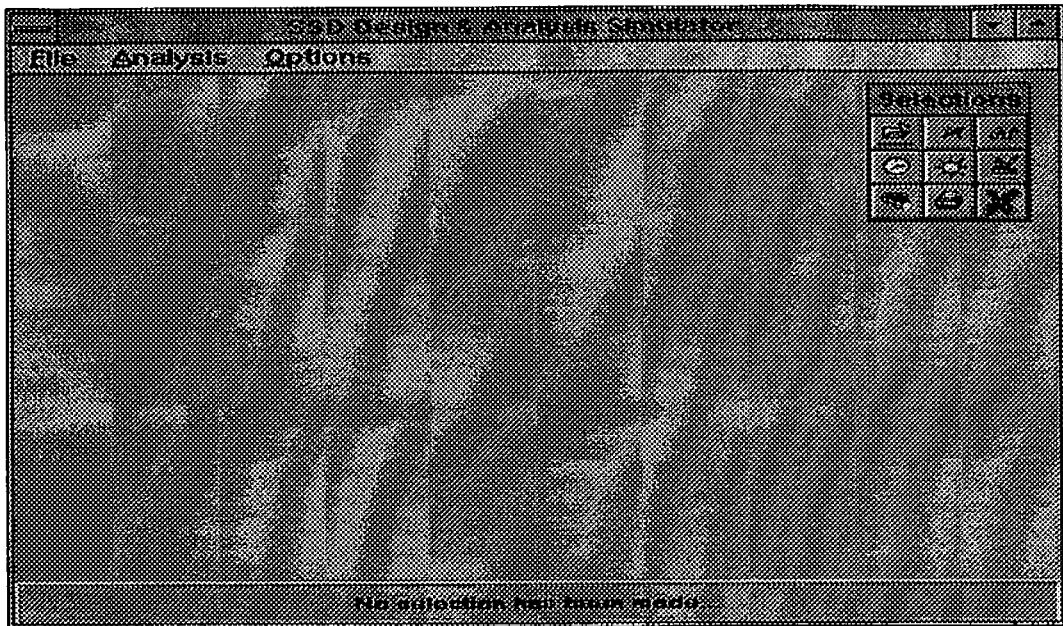

Figure 1: The main window of the PFE simulation program.

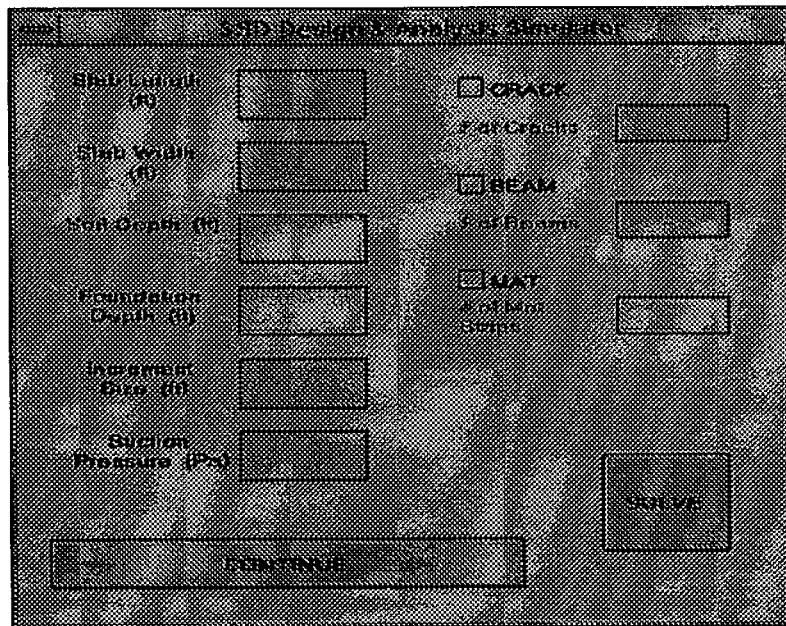

Figure 2: The Analysis menu of the PFE simulation program.

Mat Info

FOR MAT #

PLEASE ENTER THE FOLLOWING

X-START INDEX

X-END INDEX

Y-START INDEX

Y-END INDEX

Figure 3: (A) The Mat information window of the PFE simulation program.

Crack Info

FOR CRACK #

PLEASE ENTER THE FOLLOWING

X-INDEX

Y-INDEX

EFFECTIVE LEAKAGE AREA

POWER INDEX

Figure 3: (B) The Crack information window of the PFE simulation program.

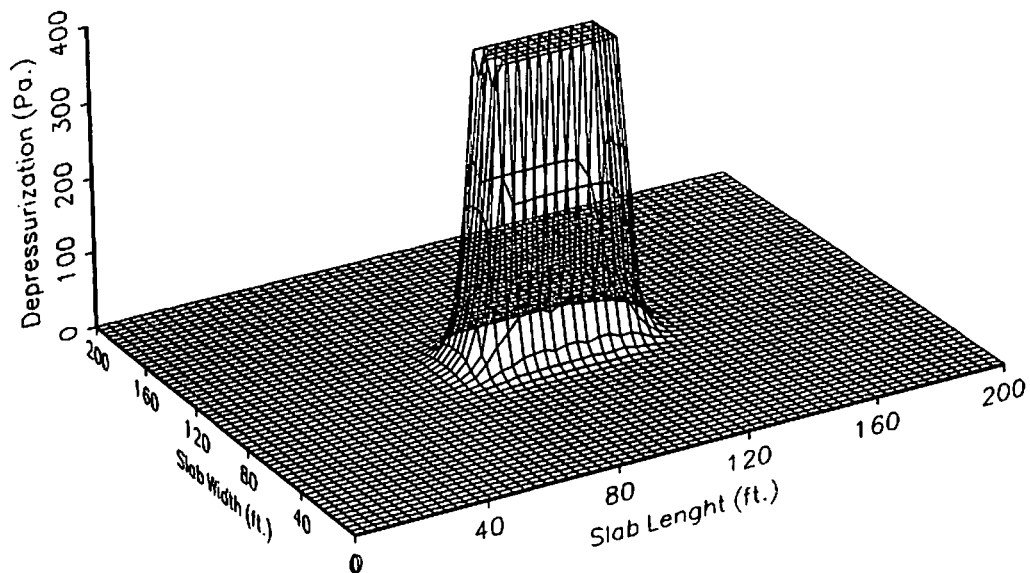

**Figure 4: Simulation of the PFE developed by an SSD system of 400 Pa installed in a 200x100 ft. slab with one suction mat extended to a 40 ft. length and 10 ft. width at the center of the slab.**

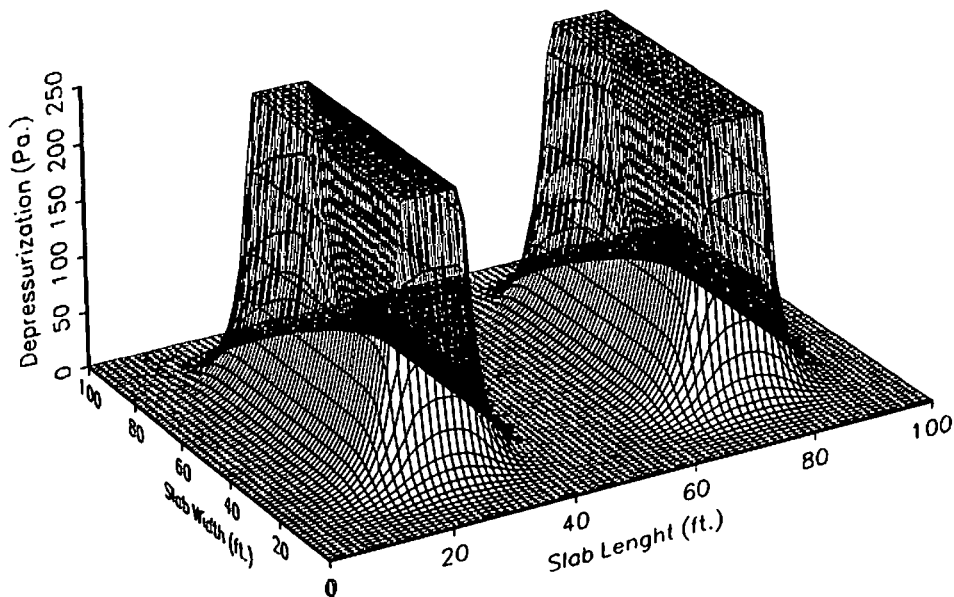

**Figure 5: Simulation of the PFE developed by a 250 Pa SSD system in a 100x100 ft. slab installed with two symmetric mats.**

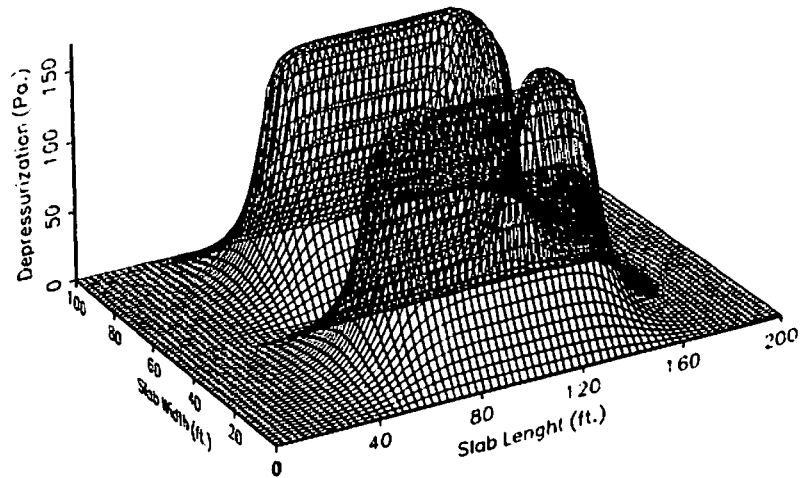

**Figure 6: Simulation of the PFE at a two foot depth under a 200x100 ft. slab developed by a 200 Pa SSD system installed with U-shape matting. The slab is built with a two foot grade beam.**