

1994-18

## MEASUREMENT OF $^{220}\text{Rn}$ (THORON) USING ELECTRET ION CHAMBERS

Paul Kotrappa and Lorin Stieff  
Rad Elec, Inc.  
Frederick, MD

J. Bigu  
CANMET, Elliot Lake Laboratory  
Elliot Lake Ontario, CANADA

### ABSTRACT

Recently there has been an increased interest in the measurement of airborne  $^{220}\text{Rn}$  (thoron). Such measurements are particularly targeted in areas rich in thorium, and in facilities processing thorium compounds and associated radioactive wastes. Standard electret ion chambers (E-PERMS<sup>®</sup>) designed for making indoor and outdoor  $^{222}\text{Rn}$  (radon) measurement have very little response to  $^{220}\text{Rn}$  (thoron). However, such units when modified by increasing the area of the filtered inlets respond to  $^{220}\text{Rn}$  (thoron). Such units, termed as thoron E-PERMS were calibrated and tested in Canadian National Thoron Testing Facility located at Elliot Lake. The paper describes the procedures for making  $^{220}\text{Rn}$  measurements in air using these modified E-PERMS.

### INTRODUCTION

The Electret Ion Chamber (EIC) is an integrating ionization chamber wherein the electret (a charged Teflon Disc) serves both as a source of electrostatic field and as a sensor. It consists of an electret mounted inside a small chamber made of electrically conducting plastic. These are passive devices. The ions produced inside the chamber are collected onto the electret causing a reduction of the charge on the electret. the reduction in charge is a measure of the total ionization produced during that period in that volume of the chamber. The charge on the electret before and after the exposure is measured by a sensitive electret voltage reader. The sensitivity and dynamic range depends upon the thickness of the electret and on the volume of the chamber. The "S" type of chamber has an on/off mechanism which can be used to close and open the electret from outside. Electrets of two different thicknesses are commercially available. The electret with the 1.542 cm is usually referred to as "short term" or "high sensitivity" electret and the electret with 0.127 mm is referred to as "long term" or "low sensitivity" electret. the scientific basis and the design features are described in publications cited (1,2).

### INTRODUCTION

The standard E-PERMS are designed to minimize the response to  $^{220}\text{Rn}$  (thoron) by restricting the diffusion entry time. This is achieved by having a very small area filter for the passive diffusion. Because of very short half life (about one minute), it decays before entering the active area of the E-PERM. The chamber of such unit was modified by increasing the filtered diffusion area from 0.3 cm<sup>2</sup> to 30 cm<sup>2</sup> to allow thoron to diffuse into the chamber with very little delay time. Such modified unit is called as radon thoron E-PERM or RT E-PERM because it responds to both radon and thoron. This paper presents the calibration of these devices.

## DESCRIPTION OF RADON-THORON E-PERMS

Figure 1 gives a schematic view of the R E-PERM and Figure 2 gives a schematic of modified R E-PERM called as R-T E-PERM. A series of holes were drilled in the body of the chamber, and the holes subsequently covered with an electrically conducting filter paper(carbon coated Tyvek paper of 0.06 mm thickness). The area of the opening was about 30 cm<sup>2</sup>.

### CALIBRATION

A set of 5 RT E-PERMS with ST electrets and a set of 5 R E-PERMS with ST electrets were exposed simultaneously in a known thoron atmosphere in the thoron test facility of CANMET, Elliot Lake Laboratory, Mining Research Laboratory, Elliot Lake, CANADA.

This test facility is one of the very few laboratories in the world capable of giving well characterized thoron concentration for testing thoron detectors and was recently used for International Intercomparison exercises.

The electrets of both RT and R E-PERMS were read before introducing the detectors into the test facility, and subsequently read after 2 days, 3 days and after 4 days. Results are in Table-1. I and J are the initial and final voltages of electrets used in RT E-PERMS, K and L are the initial and final voltages of electrets used in R E-PERMS. T is the average thoron concentration in the testing zone. D is the exposure time in days.

The R E-PERM responds to radon, ambient gamma. The RT E-PERM responds to radon, ambient gamma and to thoron. The differential signal, [(I-J) - (K-L)] is therefore uniquely related to thoron concentration. The equation (1) gives the definition of the calibration factor applicable to this pair of units while measuring thoron concentration in air.

$$\boxed{Tn\left(\frac{pCi}{l}\right) = \frac{(I - J) - (K - L)}{CF \times D}} \quad \text{Equation (1)}$$

Where CF is the thoron calibration factor for the paired measurement.

Table-1 gives the calculated CF for different exposure time for all the E-PERMS. The average CF calculates to be 0.7696. This calibration factor holds good for the mid point voltages (MPV) in the range of about 600 to 700 volts. It is known that the CF values for typical E-PERMS do slowly vary with MPV. Assuming that the variation of CF with MPV for thoron is similar to that between CF and MPV for radon (1,2) and Equation (2) is usable for calculating the CF for any MPV.

$$\boxed{(ST) = 0.6223 + 0.00021 \frac{(I + J)}{2}} \quad \text{Equation(2)}$$

### MIXTURE OF RADON AND THORON

The analysis of the paired units leads to correct thoron concentrations irrespective of the presence of radon. In order to resolve both radon and thoron concentrations from the parameters obtained in paired measurements, it is necessary to have radon equivalent signal for R chamber from thoron.

An experiment was done in a relatively pure thoron atmosphere created by blowing air over a thorium source in an enclosed atmosphere. Radon concentration in that enclosure was determined before starting the experiment and it was 2 pCi/L. by subtracting the voltage drop expected from the radon (2 pCi/L) and gamma radiation (8 uR/h) from the total voltage drop, it is possible to get the net voltage drop due to thoron only. The data of such experiment is given in Table-2. This works out to be 15 volts for 165 pCi/L-day of thoron. Therefore, the thoron calibration factor of R chamber is 0.091 volt per pCi/L-day for a mid point voltage of 660 V. For the same mid point voltage, the radon calibration factor for R chamber is 2.308 volt per pCi/L-day (1,2). If we divide the two, we get the radon equivalent of thoron. This works out to be 0.039. This means one pCi/L of thoron gives an equivalent of 0.039 pCi/L of radon. When an R chamber is used in the presence of thoron, the contribution from the thoron should be subtracted to arrive at net radon concentration.

Equation (3) is used for calculating radon concentration where both radon and thoron are present.

$$\boxed{Rn\left(\frac{pCi}{l}\right) = R - (0.039 \times T)} \quad \text{Equation (3)}$$

Where R is the radon concentration calculated by standard method using initial and final voltages K and L. T is the thoron concentration determined by the paired data.

The data in Table-1 was obtained in a thoron test chamber which also contains radon. Let us calculate the radon concentration for the data in row 1 of Table-1, assuming the ambient gamma radiation level as 10 uR/h. Using the voltage readings K and L, standard procedure leads to a radon concentration of 8.1 pCi/L. Using equation (3) and correcting for the contribution from thoron, the final radon concentration works out to be 4.8 pCi/L.

## DISCUSSIONS AND CONCLUSIONS

The principle of using larger filtered inlet area to increase the response of a radon detector to thoron was used first used by Pearson (6). This method was adopted for alpha track detectors. The calibration was done at very high concentrations (1000 to 20,000 pCi/L-days) compared to the concentration used (80 to 320 pCi/L-days). This was because of the sensitivity limitations of alpha track detectors. The E-PERM technique appears to give a practical method of measuring thoron concentrations usually found in homes. It is possible to resolve the concentrations of radon and thoron when used in an atmosphere containing both radon and thoron.

## REFERENCES

1. Kotrappa, P. Dempsey, J.C , Hickey, J.R. Stieff, L.R. An electret passive environmental radon monitor based on ionization measurement Health Physics 54:47-56, 1988
2. Kotrappa, P. Dempsey, J.C. Stieff, L.R. Ramsey, R.W. A practical electret passive environmental radon monitors for indoor radon measurement. Health Physics 58:461-467, 1990
3. Pearson, M.D. Calibration of alpha track monitors for measurement of thoron (Rn-220) Proceedings of International Symposium on Radon and Radon Reduction Technolgy. United States Environmental Protection Agency. Atlanta., GA 1990.

TABLE-1

THORON CALIBRATION DATA FOR MODIFIED S CHAMBER E-PERMS

	RT E-PERM	R E-PERM	I	J	K	L	T	D	CF	AV.CF
E,5	SK3649	SK3662	748	590	748	706	84.4	2	0.0288484	
F,6	SK3602	SK3705	739	567	742	706	84.4	2	0.8056872	
G,7	SK3776	SK3552	717	536	748	701	84.4	2	0.7938389	
H,8	SK3740	SK3599	748	617	752	712	84.4	2	0.5390995	
I,9	SK3703	SK3715	739	591	740	704	84.4	2	0.6635071	0.0288484
E,5	SK3649	SK3662	748	500	748	685	84.4	3.0104	0.7281235	
F,6	SK3602	SK3705	739	467	742	676	84.4	3.0104	0.8107754	
G,7	SK3776	SK3552	717	435	748	676	84.4	3.0104	0.8265186	
H,8	SK3740	SK3599	748	545	752	690	84.4	3.0104	0.5549482	
I,9	SK3703	SK3715	739	503	740	683	84.4	3.0104	0.7045087	
										0.8107754
E,5	SK3649	SK3662	748	424	748	667	84.4	3.9896	0.7216631	
F,6	SK3602	SK3705	739	381	742	657	84.4	3.9896	0.8107573	
G,7	SK3776	SK3552	717	344	748	657	84.4	3.9896	0.8374855	
H,8	SK3740	SK3599	748	480	752	675	84.4	3.9896	0.5672331	
I,9	SK3703	SK3715	739	420	740	666	84.4	3.9896	0.7276027	
										0.8107573
									Grand Avg	0.550127
									STD %	67.002643

I AND J ARE THE INITIAL AND FINAL READINGS OF RADON-THORON E-PERM  
 K AND L ARE THE INITIAL AND FINAL READINGS OF RADON E-PERM  
 D IS THE EXPOSURE IN DAYS, T IS THE THORON CONCENTRATION IN PCI/L  
 CF IS THE CALIBRATION FACTOR IN VOLTS PER PCI/L-DAYS  
 APPLICABLE TO THE DIFFERENTIAL SIGNAL BETWEEN RT CHAMBER AND R CHAMBER

TABLE-2

## EXPOSURES IN RELATIVELY PURE THORON CHAMBER

	RT E-PERM	R E-PERM	I	J	K	L	D	T	R
J,6	SL4773	SM3451	572	429	676	656	1	169.0942	2
K,7	SM4775	SM4782	637	494	670	648	1	163.2807	2

I AND J ARE THE INITIAL AND FINAL READINGS OF RADON-THORON E-PERM

K AND L ARE THE INITIAL AND FINAL READINGS OF RADON E-PERM

D IS THE EXPOSURE IN DAYS, T IS THE CALCULATED THORON CONCENTRATION IN PCI/L

R IS THE RADON CONCENTRATION IN PCI/L

# E-PERM<sup>®</sup>

## Electret-Passive Environmental Radiation Monitor (Schematic)

ELECTRET

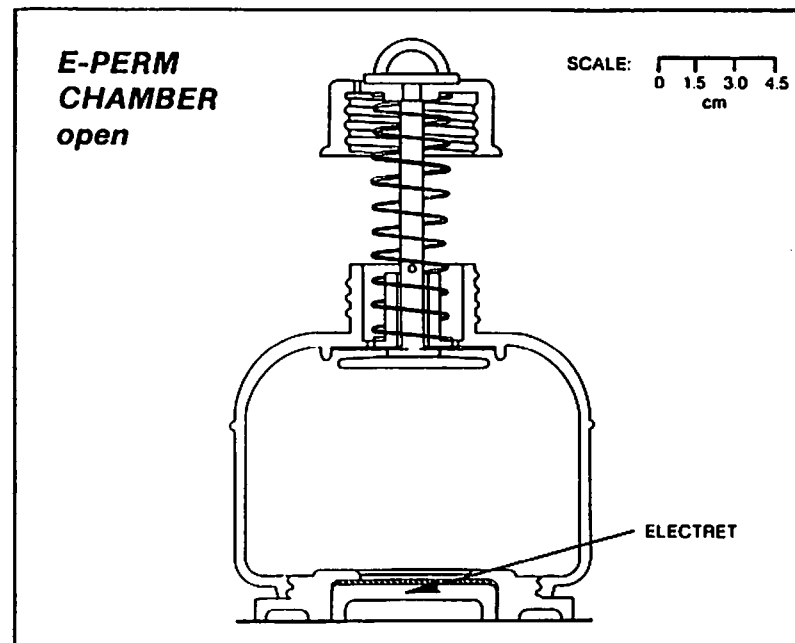
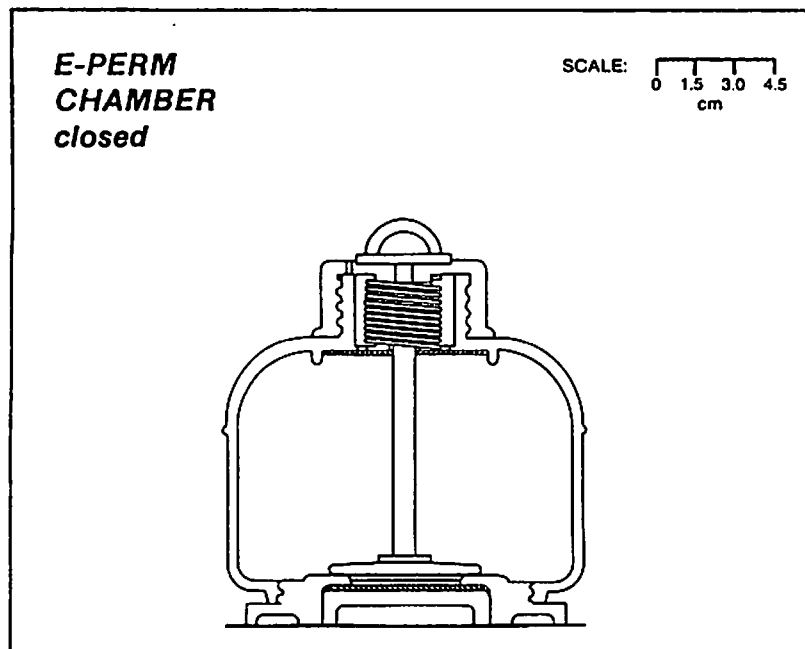

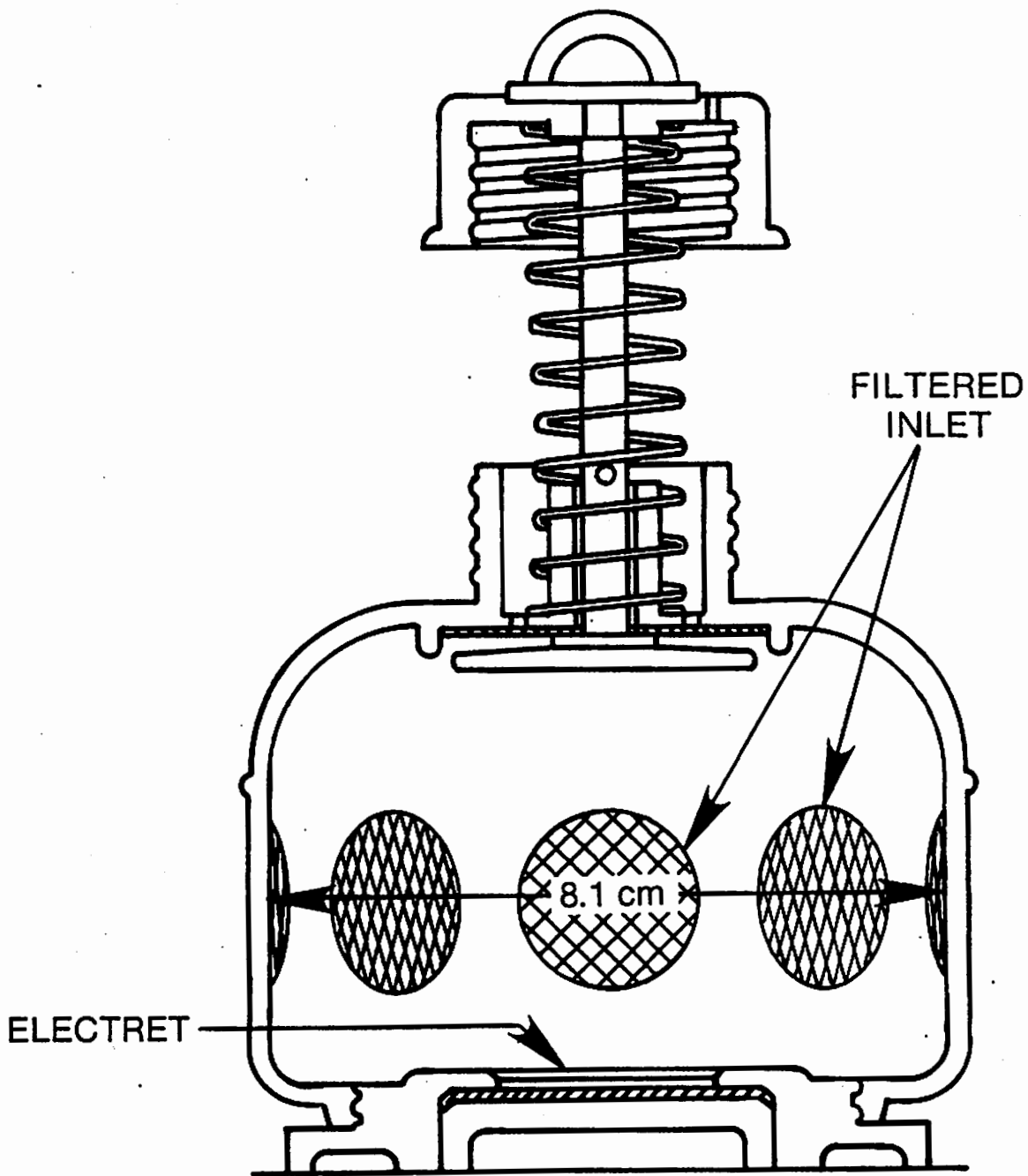

**210 mL CHAMBER**